



**ANUP EXIM**  
BE GLOBALLY CONNECTED



# DOOR CLOSER



+91 8200 907 903



[INFO@ANUPEXIM.COM](mailto:INFO@ANUPEXIM.COM)



57 G.I.D.C BHARUCH 392001 GUJ. INDIA



[WWW.ANUPEXIM.COM](http://WWW.ANUPEXIM.COM)

# DOOR CLOSER INSTALLATION

## DOOR CLOSER INSTALLATION - REGULAR ARM

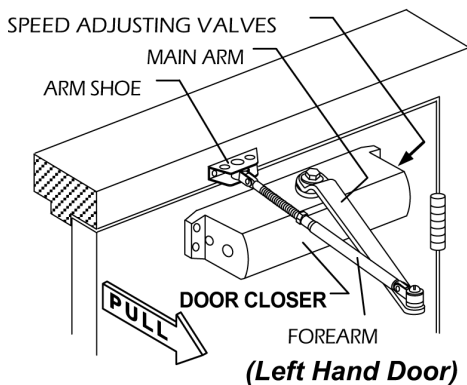
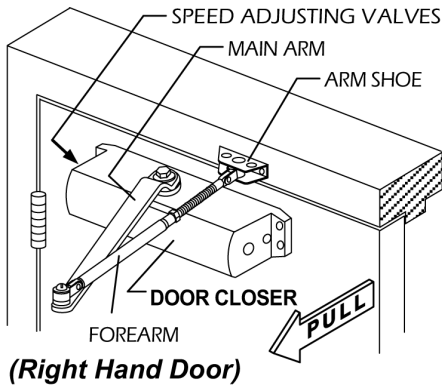

1. Using the measurements from diagram A, mark screw hole center locations. Mark four (4) hole locations on door for door closer and two (2) hole locations on frame for arm shoe.
2. Drill pilot holes in door and frame, drill 7/32(5.5mm) diameter holes for wood screws or drill and tap hole for screws.
3. Install adjustable forearm/arm shoe to frame using screws (a) or (b).
4. Mount closer on door using screws (c) or (d).  
**SPEED ADJUSTING VALVES MUST BE POSITIONED TOWARD HINGE SIDE.**
5. Install main arm to top pinion shaft, perpendicular to door, Secure tightly with arm screw/washer (e)
6. Adjust length of forearm so it is perpendicular to frame when assembled to pre loaded main arm. Secure forearm to main arm with screw/washer (f).
7. Adjust closing speed, Latching Speed by Speed Adjusting Valve.
8. Snap pinion cap over shaft at bottom of closer

## SPEED ADJUSTMENT INSTRUCTION

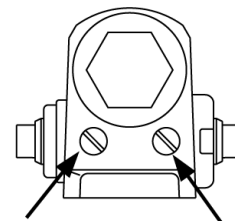
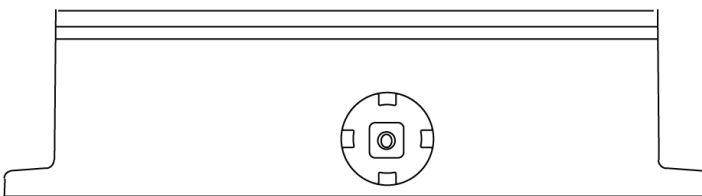

**LATCH  
Adjusting  
Valve**

**SWEEP  
Adjusting  
Valve**

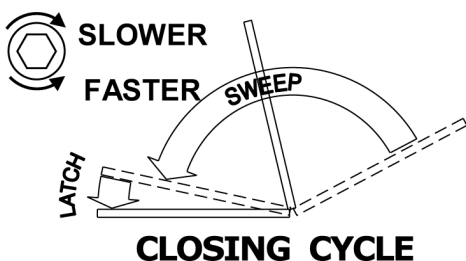

**CAUTION!!** Do not turn speed adjusting valves more than two (2) full turns counter-clockwise Otherwise a leak will result

# DOOR CLOSER

## DOOR CLOSER (DC-05) - 60 KG



**Product Code**

A481680101  
A481680102

**Size & Type**

60 KG - Hold Open  
60 KG - Non Hold Open

- Finish** : Aluminum Silver Finish
- Material** : High Grade Aluminum
- Specification** : Hydraulic Closing with two stage closing,  
Available in Standard Arm & Hold Open Arm  
Can be fitted in wooden or Metal Frame Door  
Non Handed Design  
Maximum Opening Angle 180°  
Fully Hydraulic controlled Closing Speed  
Adjustable Section of Closing speed 0°-20°  
Adjustable Section of Latching Speed 20°-180°  
Maximum Door Weight - 60 Kg  
Maximum Door Width - 900mm

## DOOR CLOSER - 40 KG



- Finish** : Aluminum Silver Finish
- Material** : High Grade Aluminum
- Specification** : Hydraulic Closing with two stage closing,  
Available in Standard Arm & Hold Open Arm  
Can be fitted in wooden or Metal Frame Door  
Non Handed Design  
Maximum Opening Angle 180°  
Fully Hydraulic controlled Closing Speed  
Adjustable Section of Closing speed 0°-20°  
Adjustable Section of Latching Speed 20°-180°  
Maximum Door Weight - 40 Kg  
Maximum Door Width - 800mm

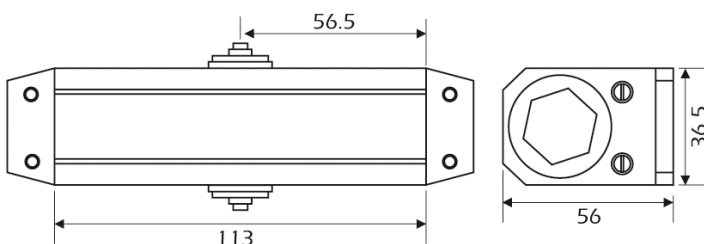

**Product Code**

A481680201  
A481680202

**Size & Type**

40 KG - Hold Open  
40 KG - Non Hold Open

# DOOR CLOSER

## DOOR CLOSER - 60 KG



**Finish** : Aluminum Silver Finish

**Material** : High Grade Aluminum

**Specification** : Hydraulic Closing with two stage closing,  
Available in Standard Arm & Hold Open Arm  
Can be fitted in wooden or Metal Frame Door  
Non Handed Design  
Maximum Opening Angle 180°  
Fully Hydraulic controlled Closing Speed  
Adjustable Section of Closing speed 0°-20°  
Adjustable Section of Latching Speed 20°-180°  
Maximum Door Weight - 60 Kg  
Maximum Door Width - 950mm

**Product Code**

A481690101  
A481690102

**Size & Type**

60 KG - Hold Open  
60 KG - Non Hold Open

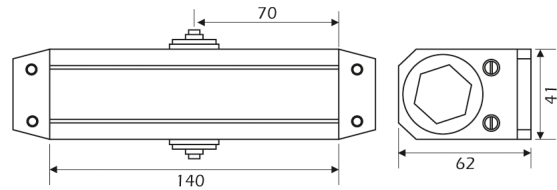

## DOOR CLOSER - 80 KG



**Finish** : Aluminum Silver Finish

**Material** : High Grade Aluminum

**Specification** : Hydraulic Closing with two stage closing,  
Available in Standard Arm & Hold Open Arm  
Can be fitted in wooden or Metal Frame Door  
Non Handed Design  
Maximum Opening Angle 180°  
Fully Hydraulic controlled Closing Speed  
Adjustable Section of Closing speed 0°-20°  
Adjustable Section of Latching Speed 20°-180°  
Maximum Door Weight - 80 Kg  
Maximum Door Width - 1100mm

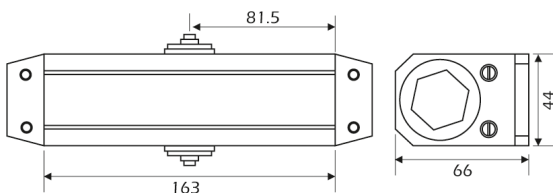

**Product Code**

A481690201  
A481690202

**Size & Type**

80 KG - Hold Open  
80 KG - Non Hold Open

# DOOR CLOSER

## DOOR CLOSER (DC-07) - 80 KG



**Finish** : Aluminum Silver Finish

**Material** : High Grade Aluminum

**Specification** : Hydraulic Closing with two stage closing,  
Can be fitted in wooden or Metal Frame Door  
Non Handed Design  
Maximum Opening Angle 120°  
Adjustable Section of Closing speed 0°-20°  
Adjustable Section of Latching Speed 20°-120°  
Maximum Door Weight - 80 Kg  
Maximum Door Width - 1100mm

**Product Code**

A4817001

**Size & Type**

80 KG - Non Hold Open

## DOOR CLOSER PALMET - 80 KG



**Finish** : Aluminum Silver Finish

**Material** : High Grade Aluminum

**Specification** : Hydraulic Closing with two stage closing,  
Can be fitted in wooden or Metal Frame Door  
Non Handed Design  
Maximum Opening Angle 120°  
Adjustable Section of Closing speed 0°-20°  
Adjustable Section of Latching Speed 20°-120°  
Maximum Door Weight - 80 Kg  
Maximum Door Width - 1100mm

**Product Code**

A4817002

**Size & Type**

80 KG - Non Hold Open

# DOOR CLOSER

## CONCEAL DOOR CLOSER - 80 KG



**Finish** : Aluminum Silver Finish

**Material** : High Grade Aluminum

**Specification** : Hydraulic Closing with two stage closing,  
Can be fitted in wooden or Metal Frame Door  
Suitable for 35mm or more thickness of Door  
Fully Hydraulic controlled Closing Speed  
Pack body to ensure Long Life  
Adjustable Closing speed  
Adjustable Latching Speed  
Maximum Door Weight - 60 to 80 Kg  
Maximum Door Width - 950mm

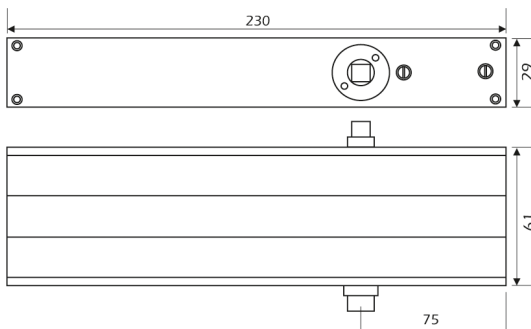

### Product Code

A4817101

### Size & Type

80 KG - Hold Open

# Thank You



[+91 8200 907 903](tel:+918200907903)



[INFO@ANUPEXIM.COM](mailto:INFO@ANUPEXIM.COM)



[57 G.I.D.C BHARUCH 392001 GUJ. INDIA](#)



[WWW.ANUPEXIM.COM](http://WWW.ANUPEXIM.COM)